

Lithium SuperPack NG manual

12,8V/100Ah | 12,8V/200Ah | 25,6V/100Ah | 25,6V/
200Ah | 51,2V/100Ah

Table of Contents

1. Safety Precautions	1
1.1. General Warnings	1
1.2. Charge and Discharge Warnings	2
1.3. Transportation Warnings	3
1.4. Disposal of Lithium Batteries	3
2. Introduction	4
2.1. Features	4
2.2. Product Overview	5
3. Installation	6
3.1. Unpacking and Handling the Battery	6
3.2. Download and Install VictronConnect	6
3.3. Updating Battery Firmware	6
3.4. Mounting the Battery	6
3.5. Electrical Installation	7
3.5.1. Connecting multiple batteries in parallel	8
3.6. External Feedback Signal (EFS) – Function and Wiring	9
4. Configuration & Settings	14
4.1. Configuration of chargers and loads	14
4.2. Lithium SuperPack NG battery settings	15
5. Operation	16
5.1. Monitoring & Control via VictronConnect	16
5.1.1. Instant Readout	19
5.2. Charging	20
5.3. Discharging	21
5.4. Reset to factory defaults	22
5.5. Bluetooth reactivation	22
6. Troubleshooting	23
6.1. LEDs, Warnings, Alarms & Error Codes	23
6.2. Self-restoring protection mechanisms	25
6.2.1. Very low battery voltage recovery procedure	26
6.3. ATC / ATD off-reasons in VictronConnect	27
7. Technical Data	28
7.1. Battery Specification	28
7.2. Enclosure Dimensions	31

1. Safety Precautions



- Observe these instructions and keep them located near the battery for future reference.
- The Material Safety Datasheet can be downloaded from the “Material Safety Datasheet menu” located on the [Lithium Smart product page](#).
- Work on a lithium battery must be carried out by persons familiar with lithium battery systems.

1.1. General Warnings

- While working on a lithium battery, wear protective eyeglasses and clothing.
- Any leaked battery material, such as electrolyte or powder on the skin or the eyes, must immediately be flushed with plenty of clean water. Then seek medical assistance. Spillages on clothing should be rinsed out with water.
- The 3/4” threaded connection is provided solely for venting possible gases. It is not designed for cooling the battery and must not be connected to water, liquids, or any other media.
- In the event of fire, overheating, or gas release, use suitable firefighting and cooling measures. CO₂, ABC, or foam extinguishers can help suppress flames initially, but they may not prevent re-ignition during thermal runaway. In the event of thermal runaway, disconnect the battery (if safe to do so) and apply intensive cooling using large amounts of water. As a rule of thumb, fully submerge the battery in water at about 20 °C, using a water volume of at least twice the battery volume. Always follow local fire authority guidance.
- The terminals of the lithium battery is live when the battery is switched on or in the event of an internal fault. Do not place metallic objects or tools on top of the battery.
- For maintenance or when working on or near the battery, always switch the battery off before you start. This maximises safety and helps prevent short-circuit and electric shock hazards.
- Use insulated tools.
- Do not wear any metallic items such as watches, bracelets, rings, etc. during installation and service.
- Avoid short circuits, very deep discharges and excessive charge or discharge currents.



- If the battery casing is damaged, do not touch any exposed material, electrolyte, or powder. These substances may be harmful and cause irritation.
- Lithium batteries are heavy. To avoid muscle strain or back injury, use lifting aids and proper lifting techniques when installing or removing batteries.
- If involved in a vehicle accident, they can become a projectile! Ensure adequate and secure mounting and always use suitable handling equipment for transportation.
- Handle with care because a lithium battery is sensitive to mechanical shock.
- Do not use a damaged battery.
- The battery is splash-resistant (IP65) but not suitable for immersion. If the battery has been submerged in water, discontinue use and seek further advice.

1.2. Charge and Discharge Warnings



- Overcharging or deep discharging can seriously damage a lithium battery and may render it unsafe for continued use. An external safety relay in combination with the EFS signal is recommended as redundant protection in addition to the internal BMS.
- Under extreme fault conditions, such as severe internal failure or multiple protection mechanisms failing, the battery may release gases through its internal safety valve. The 3/4-inch threaded connection is provided to allow controlled venting of such gases. It must not be obstructed.
- The Lithium SuperPack NG battery is capable of absorbing high levels of energy. If the primary charging source does not provide effective current limiting, it is strongly recommended to add an external current-limiting device to prevent overloading the charger and associated wiring.
- Battery service life depends on the application. Published life-cycle data is referenced at 25 °C and assumes charge and discharge currents not exceeding 0,5C, with the specified depth of discharge.
- The battery may be used in ambient temperatures from -30 °C to +60 °C. However, charging is only permitted when the cell temperature is within a safe charging range. If the cell temperature is below 0 °C, the BMS suspends charging and the internal self-heating function warms the cells; charging resumes automatically once a safe charging temperature is reached.
- The battery's discharge temperature range is -30 °C to 60 °C. Discharging the battery at temperatures outside this range may cause severe damage to the battery or reduce its life expectancy.
- During peak power demand, the top surface of the battery may reach temperatures of up to 50 °C.

1.3. Transportation Warnings



- The battery must be transported in its original or equivalent package and in an upright position. If the battery is in its cardboard packaging, use soft slings to avoid damage. Ensure that all packaging materials are non-conductive.
- Cartons or crates used to transport lithium batteries must have an approved warning label affixed.
- Air transport of lithium batteries is subject to strict regulations. Refer to the applicable IATA Dangerous Goods Regulations and airline requirements before shipping.
- Do not stand below a battery when it is hoisted.
- Never lift the battery at the terminals; only lift the battery at the handles.



- Batteries are tested according to the UN Handbook of Tests and Criteria, part III, sub-section 38.3 (ST/SG/AC.10/11/Rev.5).
- For transport, the batteries belong to the category UN3480, Class 9, Packaging Group II and have to be transported according to this regulation. This means that for land and sea transport (ADR, RID & IMDG) they have to be packed according to packaging instruction P903 and for air transport (IATA) according to packaging instruction P965. The original packaging complies with these instructions.

1.4. Disposal of Lithium Batteries



- Do not throw a battery into fire.
- Batteries must not be mixed with domestic or industrial waste.
- Batteries marked with the crossed out bin symbol must be processed via a recognised recycling agency.

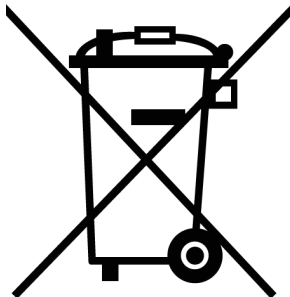

2. Introduction

The Lithium SuperPack NG batteries are Lithium Iron Phosphate (LiFePO₄ or LFP) batteries available in various capacities with nominal voltages of 12,8V, 25,6V, and 51,2V. They are designed as drop-in replacements for lead-acid batteries in mobile, marine, and industrial applications. Designed for extended off-grid use, it provides ample capacity to power the complete electrical system, including high-demand appliances. Its form factor and terminal layout ensure easy installation across a wide range of mobile and industrial applications, including commercial and recreational vehicles.

2.1. Features

- **Embedded protection**

The integrated Battery Management System (BMS) provides a layer of protection that ensures energy flow remains within the safe operating limits of the battery and the overall system.

- **Energy flow management**

Capable of interrupting charging and discharging independently through its self-resetting circuit breaker.

- **Continuous current capability**

Supports continuous discharge currents up to 2C and continuous charge currents up to 1C, reducing the need to oversize the battery pack.

- **Internal cell balancing**

Allows the battery to maintain optimal voltage balance at the end of the charging process.

- **Bluetooth monitoring and control**

Integrated Bluetooth interface for real-time monitoring and control of the battery via VictronConnect.

- **On/Off push button**

Push button for switching the battery on or off, disabling both charging and discharging. The on/off procedure can also be used to reset certain protection or lock-in conditions. When switched off, the battery enters a storage mode with a self-discharge rate of less than 3% per month.

- **LED status indication**

Two integrated LEDs indicate Bluetooth connectivity, warning and alarm conditions, and firmware update status.

- **External Feedback Signal (EFS)**

Provides a battery voltage signal limited to 250 mA. The EFS signal serves as an External Disconnection Signal (EDS) to trigger an event for redundant system protection. Additionally, the EFS can be configured as an External Charging Signal (ECS), based on the low SoC pre-alarm threshold, to activate a charger start signal.

- **Self-heating function**

Maintains the battery temperature above the minimum safe charging limit to ensure reliable operation in cold environments. Two heating modes are available:

- **Charger mode** – the heater is powered by the connected charger and activates automatically when the cell temperature drops below 0 °C during charging (default setting).
- **Auto mode** – the battery powers the heater to keep the cells above 0 °C for immediate charging. This is limited by the battery's internal energy; if SoC falls below the Low SoC threshold, the heater is disconnected and charging remains unavailable.

The internal heat balancer supports optimised thermal management and a wide operating range.

- **High efficiency**

- Operating efficiency 93 %
- High round-trip efficiency
- High energy density (up to 170 Wh/dm³ and 128 Wh/kg) - more capacity with less weight and volume

- **Parallel connection**

Supports parallel connection of an unlimited number of batteries to increase total energy capacity. The total system current should not exceed the maximum current that a single battery can safely interrupt (refer to [Battery Specification \[28\]](#) for details).

- **BCI Group 49 compatibility**

Height dimension is compatible with the BCI Group 49 standard, allowing easy replacement in standard battery compartments.

- **Mounting brackets**

Mounting brackets are included to ensure safe and stable fixing in all three axes.

- **Ingress protection (IP65)**

The battery enclosure is rated IP65, providing protection against dust ingress and low-pressure water jets from any direction.

- **Self-restoring protection**

Certain protection events are automatically cleared without user intervention. The battery allows multiple automatic recovery attempts for short-circuit and over-current conditions, reducing the need for manual reset in the case of occasional or transient faults. For details, please see the [Self-restoring protection mechanisms \[25\]](#) section.

- **Safety vent (3/4" threaded connection)**

The battery is equipped with a safety vent featuring a 3/4" internal thread for connection to a gas discharge fitting. A suitable gasket must be used to ensure a proper seal. The vent is intended exclusively for the controlled release of gases in the event of extreme fault conditions. It must not be used for cooling or for the connection of liquids or other media.

2.2. Product Overview

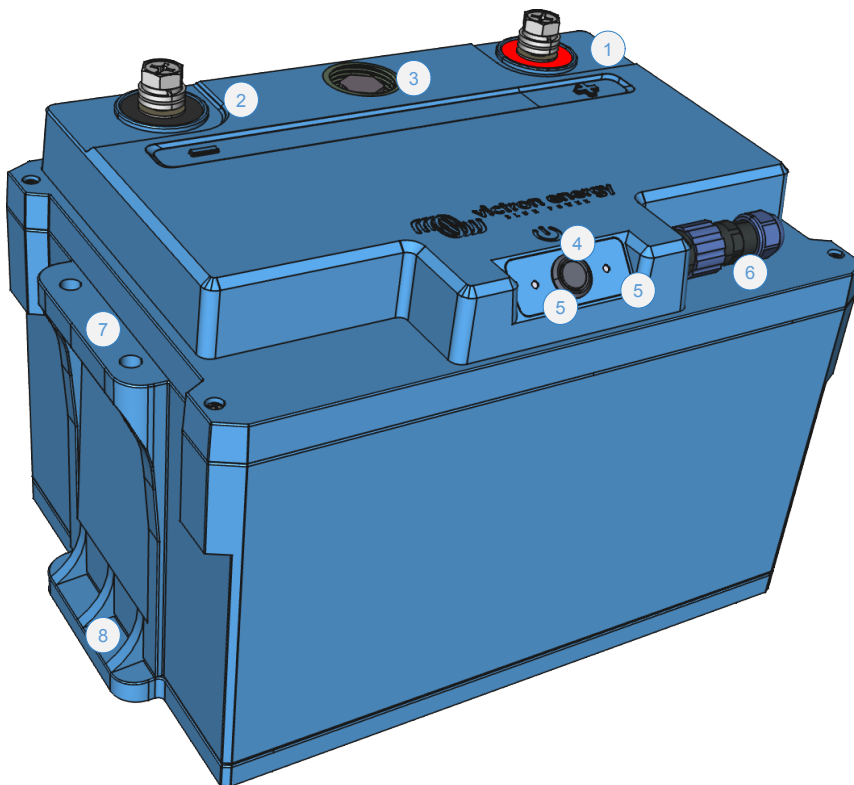

1. Positive terminal (M8)
2. Negative terminal (M8)
3. Safety vent (G3/4" BSPB threaded connection)
4. Push button for On/Off/Reset
5. Status LEDs (Bluetooth, Warning, Alarm, Firmware update status)
6. External Feedback Signal connector for SuperPack NG (included) - Victron part number: SPR00310
7. Handle brackets (carry handles not shown)
8. Mounting bosses for brackets

3. Installation

3.1. Unpacking and Handling the Battery

Handle the battery with care during unpacking. Batteries are heavy; do not lift the battery by its terminals. Use the carry handles located on both sides. The weight is specified in the [Battery Specification \[28\]](#).

Before installation, familiarise yourself with the battery layout. The main terminals on the top are marked with “+” (positive) and “-” (negative) to ensure correct polarity.

3.2. Download and Install VictronConnect

Download the VictronConnect app for Android, iOS or macOS from their respective app stores. For more information about the app, see the [VictronConnect product page](#).

3.3. Updating Battery Firmware

Updating the firmware via VictronConnect

The battery firmware can be updated via the VictronConnect app.

- Ensure that the latest version of VictronConnect is installed, as this provides access to the most recent firmware.
- A new battery is charged to a maximum of 30 % SoC. Fully charge the battery before performing a firmware update.
- On first connection, the app may prompt to update the battery firmware. If prompted, allow the update to complete.
- Before updating, refer to the [firmware update chapter](#) in the VictronConnect manual for detailed instructions.

General notes on firmware updates

- **Newer isn't always better** – only update if necessary.
- **If it works, don't break it** – avoid unnecessary updates.
- **Read the changelog first** – available on [Victron Professional](#).

Use this feature with care. Our main advice is not to update a running system unless problems occur or before the first startup.

Notes on updating the Lithium SuperPack NG battery firmware

- The firmware update does not cause a full system shutdown.
- During the update, the Charge disconnect output opens, preventing battery charging.
- If the update fails, the Load disconnect output will open after 120 seconds as a safety measure, allowing time to retry the update.
- During a firmware update, the Bluetooth and Error LEDs blink simultaneously, indicating that the update is in progress.

3.4. Mounting the Battery

Observe the following requirements when mounting the battery:

1. The battery may be installed upright or on its long side.
Do not install the battery upside down.
2. The battery has an IP65 rating, providing protection against dust ingress and water jets. It can be installed in outdoor or semi-protected environments, but should not be exposed to direct sunlight, heavy rain, or other weather conditions.
3. Use suitable handling equipment when moving the battery.
4. Mount securely to prevent movement. In vehicles, use the supplied mounting brackets to reduce the risk of the battery becoming a projectile during an accident.
5. Allow at least 10 mm clearance on all sides to ensure adequate ventilation during charging and discharging.

⚠ Caution: An unsecured battery can become a projectile in the event of a collision or sudden stop, causing damage or injury. Always use appropriate mounting brackets.

3.5. Electrical Installation

DC wiring

- Use battery cables with a cross-sectional area suitable for the maximum expected current in the system.
- Appropriately sized cables minimise voltage drop and heat generation. Keep cable lengths equal when connecting multiple batteries in parallel.
- For most installations, the voltage drop should not exceed 2 % of the nominal system voltage.
- The wire cross-sectional area for the EFS signal wire should be at least 0,75 mm².
- All DC wiring must comply with applicable system design guidelines and local electrical installation regulations.

Fusing

- Batteries are capable of delivering very high currents; therefore, all electrical connections to the battery must be fused.
- For the main battery terminal connection, use an MRBF-type or T-type fuse with an interrupt rating (IR) of at least 10 kA.
- For the EFS signal wire, use a 315 mA fast-acting fuse, DC-rated ≥ 32 V (5×20 mm type).
- Install a suitably rated DC fuse as close as possible to the positive battery terminal.
- Install all fuses as close as possible to the positive battery terminal. Ensure that the selected fuse ratings comply with the system design guidelines and local electrical regulations.

Terminal connections

- Tighten the M8 terminal bolts to a torque of 4 Nm.
- Use the following sequence: bolt - spring washer - washer - cable lug - battery terminal.
 1. Bolt
 2. Spring washer
 3. Washer
 4. Cable lug
 5. Battery terminal
- Ensure all contact surfaces are clean, flat and securely tightened.

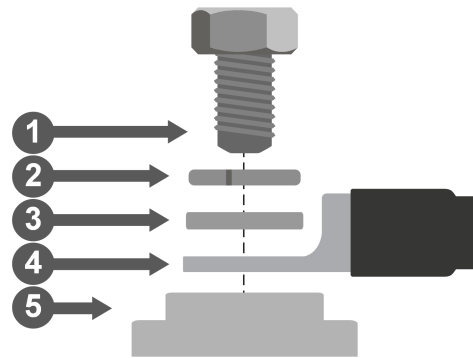

Ensure all electrical connections are correctly installed and tightened to the specified torque. Loose or high-resistance connections can cause excessive heat build-up, increasing the risk of damage or fire. Always inspect connections during installation and as part of regular maintenance.

Connection sequence

1. Connect the positive (+) cable first.
2. Connect the negative (-) cable last.
3. When disconnecting, reverse the order.
4. Consider connecting the External Feedback Signal (EFS) - see [External Feedback Signal \(EFS\) – Function and Wiring](#).



Note: This battery incorporates an internal negative switch. In OFF status or during a protection event, the negative terminal may be electronically disconnected.

3.5.1. Connecting multiple batteries in parallel

The number of batteries that can be connected in parallel is limited only by the system power. While a maximum system current applies, there is no limitation on total energy expansion. Capacity can therefore be increased without limit, whereas power expansion is restricted by the maximum system current (refer to the [Battery Specification \[28\]](#)).

- Connect the DC system cables diagonally to ensure equal current paths through each battery.
- Ensure that the cross-sectional area of the main system cable is equal to the cross-sectional area of a single string cable multiplied by the number of parallel strings.
- Fuse each battery on the positive side.
- Fuse the positive main cable leading to the battery bank.
- Connect the battery bank to the DC system.
- Fuse example:

Two batteries are connected in parallel, each with a maximum continuous current of 100 A.

Each battery must be protected by an individual fuse rated slightly above 100 A, for example a 125 A Class T fuse (or MRBF type) with an interrupt rating of 20 kA. These fuses protect the cables and the battery in case of a fault in a single string.

The total system current is the sum of the individual battery currents. In this example, the maximum system current is 200 A. The main positive system cable and the main system fuse must therefore be rated for at least 200 A (for example a 250 A Class T fuse (or MRBF type) with an interrupt rating of 20 kA).

This ensures that each battery string is correctly protected while the main fuse protects the DC system against excessive total current.

- For detailed wiring principles, calculations, and examples, refer to the [Wiring Unlimited](#) book.

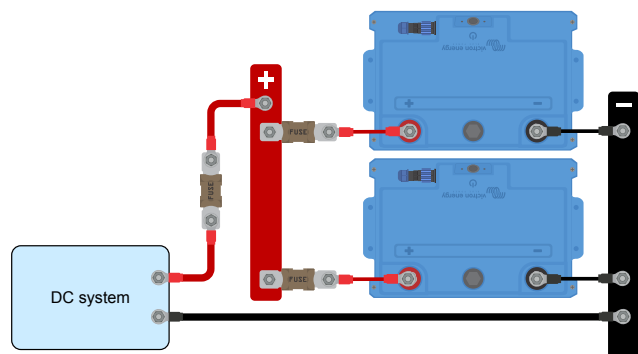

The total system current drawn from a parallel battery pack must never exceed the maximum interruptible current that a single SuperPack NG can safely interrupt (800 A). The main fuse of the battery pack must therefore not be rated above 800 A.

This ensures that, in the event of a system overcurrent, a cascading protection sequence cannot result in a situation where the final battery E-switch is required to interrupt a fault current beyond its specified capability.

Energy expansion (capacity and autonomy) can be increased by adding batteries in parallel. Power expansion, however, must be realised using multiple independent and redundantly protected battery packs.

3.6. External Feedback Signal (EFS) – Function and Wiring

The SuperPack NG battery features a M12 single-pole connector on the top panel that provides the External Feedback Signal (EFS).

The EFS connector can be associated with two functions:

- External Disconnection Signal (EDS)
- External Charging Signal (ECS)

Although both functions share the same physical EFS output, their signal behaviour and intended use are different.

General EFS characteristics

During normal operation, the EFS output is free-floating (0 V). When active, it outputs a battery-positive voltage (+V_{batt}) referenced to battery negative and can supply up to 250 mA.



Do not connect the EFS output directly to inductive, capacitive, or high-current loads. When using inductive devices such as relays or buzzers without an internal driver circuit, always fit a flyback diode across the coil (cathode to V_{batt}+).

Capacitive loads with large inrush currents should be avoided or suitably limited.

Always use the battery negative as the common reference for external devices connected to the EFS output. If multiple devices are connected, ensure that the total current remains within the output capability.

External Charging Signal (ECS)

ECS can be enabled in the VictronConnect app. When active, the EFS output is continuously high at battery-positive voltage (+V_{batt}).

ECS is triggered when the configured Low SoC warning threshold is reached. The signal remains active as long as the SoC is below the threshold or a charging current is detected. Whenever SoC is above the Low SoC threshold and no charging current is detected the ECS is deactivated.

Because ECS provides a steady ON/OFF signal, it can be used directly to:

- energise a relay coil,
- drive a visual or audible alarm,
- control devices with a remote on/off input such as a BatteryProtect, Solar Charger, or Orion XS.

External Disconnection Signal (EDS)

EDS is always enabled and provides an additional layer of system protection. When current flow is detected while ATC (Allow To Charge) or ATD (Allow To Discharge) is inactive, the EFS output generates an alternating square-wave signal.

This condition can only occur in rare fault scenarios, such as a fail-short of electronic switching devices. The internal flags allow detection of such malfunctions and enables timely intervention.

EDS is a diagnostic signal and is not intended to directly drive relays, lamps, or buzzers. When using EDS, external logic or signal conditioning is required to detect the square-wave signal and convert it into a stable control or alarm output.

EFS functional wiring examples (ECS)

Indicator light (visible alarm)

An indicator light can be connected to provide a visible alarm during ECS operation. Connect the positive lead of the light to the EFS signal pin and the negative lead to the battery negative terminal. The light illuminates continuously while the ECS signal is active.

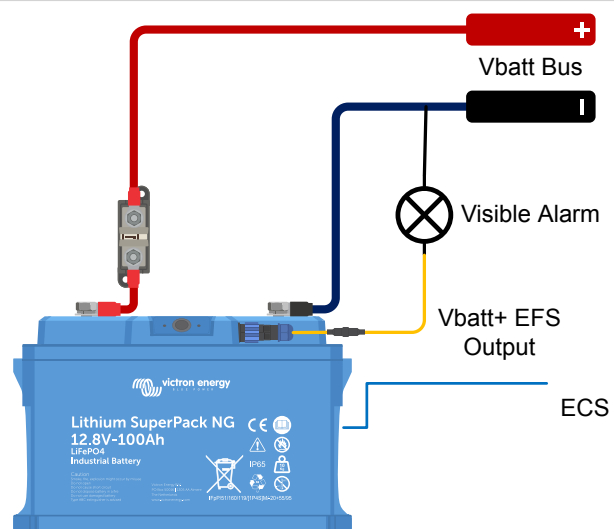

Audible alarm

An audible alarm, such as a buzzer or speaker, can be connected in the same way. The alarm sounds continuously while the ECS signal is active.

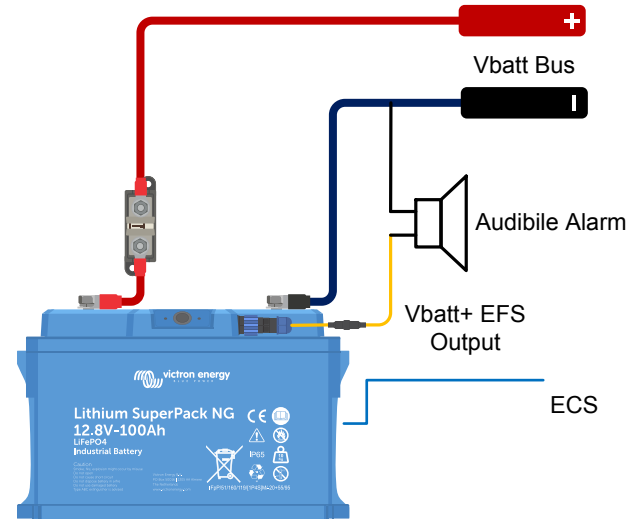

Relay-based control – alarm contact

A relay with NO/NC contacts can be driven directly by the ECS signal, as ECS provides a continuous battery-positive output. Connect the relay coil positive terminal to the EFS signal pin and the negative terminal to battery negative. When ECS is active, the relay energises and the contact can be used to switch an external alarm or signalling circuit.

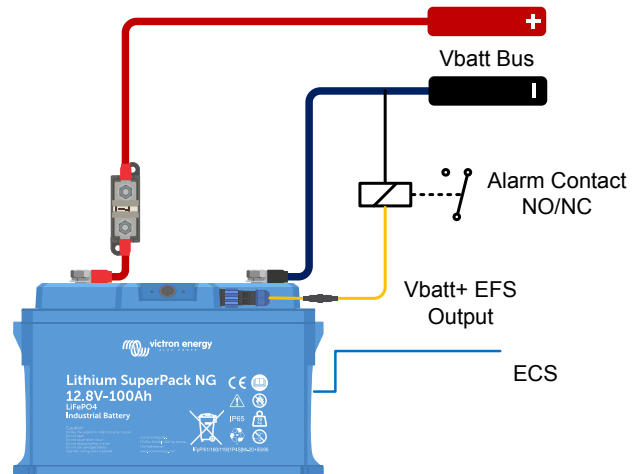

Direct control of a Victron product's remote on/off input

The ECS function can be used to control Victron products that provide a remote on/off input. It provides an automatic control signal that can be used to enable or disable external equipment based on the Low SoC threshold.

Connect the ECS output (EFS signal pin) to either the remote on/off L or H input of the device, depending on the required control behaviour for the application. Use the battery negative as the common reference (GND).

When ECS becomes active, the EFS signal goes high (+Vbatt). This activates or deactivates the device via the selected remote on/off L or H input, depending on the application. When ECS is cleared, the EFS signal returns to 0 V (free-floating) and the device reverts to its default state.

Refer to the product manual for the correct Remote on/off wiring and input requirements.

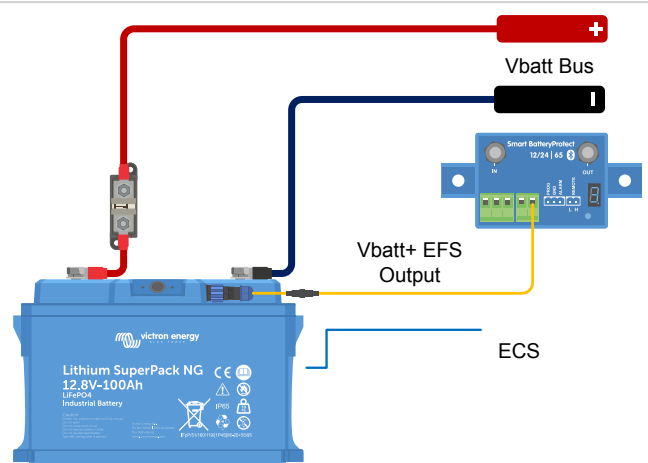

Relay-based control of a charger's remote on/off input

A relay with NO/NC contacts can be driven directly by the ECS signal. Connect the relay coil positive terminal to the EFS signal pin and the negative terminal to battery negative. When ECS is active, the relay energises and the contact can be used to control a charger or other device with a remote on/off input.

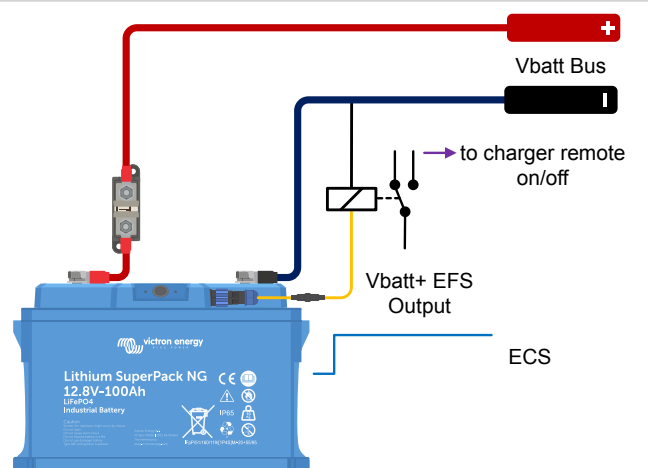

Battery bank solutions (ECS)

Parallel battery bank – ECS outputs connected in parallel

In systems with multiple Lithium SuperPack NG batteries connected in parallel, the EFS outputs of all batteries can also be connected in parallel. This ensures that when any battery triggers its EFS signal, the combined output activates, allowing connected devices or alarms to respond to a protection event from any unit in the system.

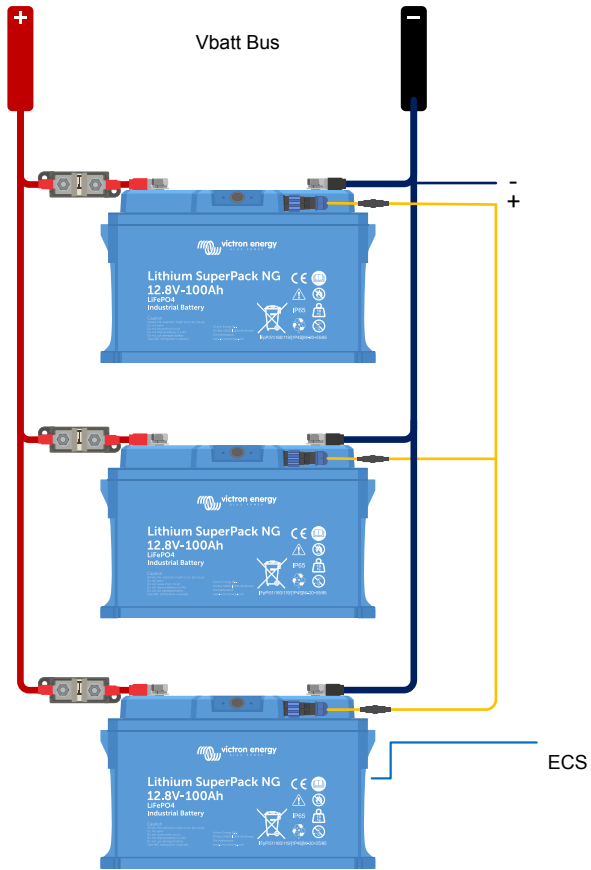

Parallel battery bank – ECS relay contacts in series

In systems with multiple Lithium SuperPack NG batteries connected in parallel, each battery can use its ECS output to drive its own relay. The relay contacts are connected in series, forming a single control path to the external device (for example, the AUX input of a MultiPlus-II).

If any battery activates its ECS signal, its relay opens and interrupts the control circuit, ensuring that the system responds immediately to a protection or warning condition from any battery.

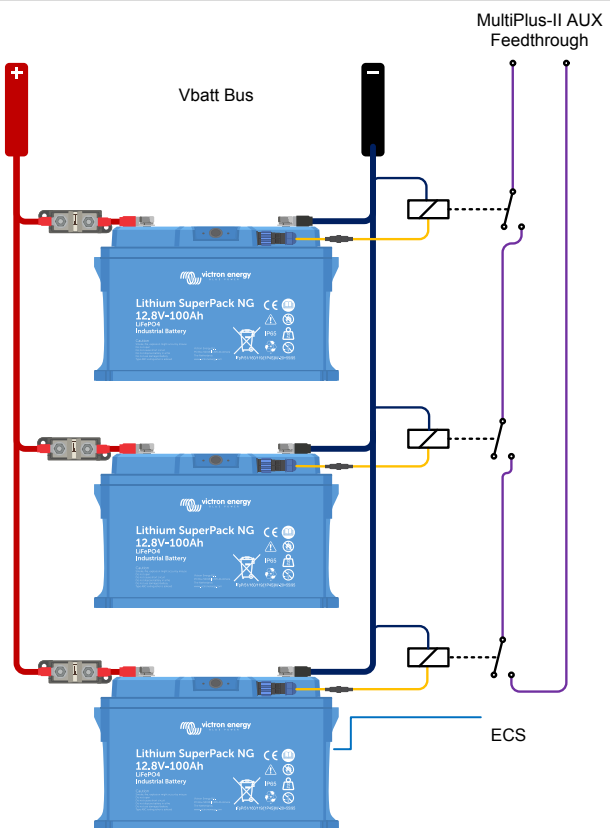

EFS functional wiring example (EDS)

The EDS output provides a square-wave diagnostic signal when an internal fault condition is detected while charging or discharging is not allowed. This signal must be connected to external logic capable of detecting the square wave and converting it into a stable alarm or shutdown signal. The EDS output must not be used to directly drive relays.

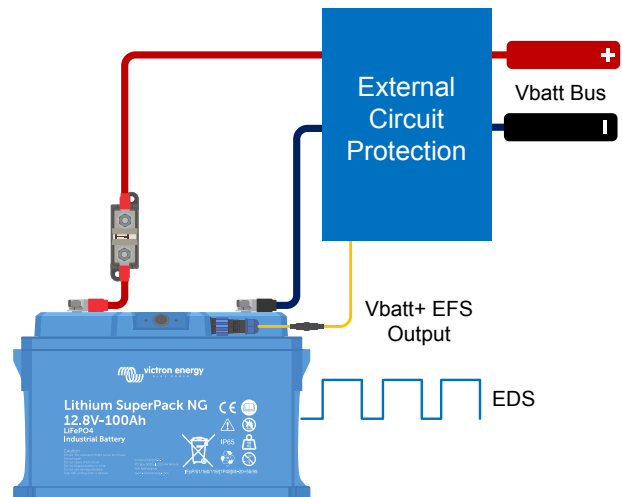

4. Configuration & Settings

4.1. Configuration of chargers and loads

Before turning on the system, ensure that chargers and loads are correctly configured, particularly their maximum combined charge and combined discharge currents, to avoid exceeding battery limits.

In addition, configure the chargers for LiFePO₄ (LFP) chemistry and set the charge voltages and related parameters according to the values listed in the [Battery Specification \[28\]](#) chapter. Use the full charge algorithm (bulk, absorption and float, where applicable) and do not use profiles intended for lead-acid batteries.

Before first use, run one complete full charge sequence. This allows the battery to initialise correctly and ensures the state-of-charge indication is accurately displayed in VictronConnect.

Maximum charge current

The maximum continuous charge current is 1C.



For optimal battery performance and lifespan, a charge current of 0.3C is recommended.

Maximum discharge current

The SuperPack NG can sustain a continuous 2C discharge current for a limited period, depending on internal temperature and cell voltage. This should be considered for peak power demand.



For continuous cycling, maximum efficiency, and best service life, limit the discharge current to 0,5C.

4.2. Lithium SuperPack NG battery settings

Once powered up, use the VictronConnect app to configure the battery settings.

BMS Settings

• Heater mode:

- **Auto:** The heater turns on when the temperature is too low to charge, even if no charger is connected. This uses battery energy.
- **Charger only:** The heater turns on only when a charger is connected, preserving battery energy.

- **External Charging Signal:** Disabled by default. When enabled, the EFS is triggered when the Low SoC warning threshold, configurable in the VictronConnect app, is reached. For details, refer to the [External Feedback Signal \(EFS\) – Function and Wiring \[9\]](#) section.

Battery monitor settings:

Unlike other battery monitors, the Lithium SuperPack NG battery has mostly fixed settings that cannot be customised.

- **Charged voltage:** The voltage above which the battery monitor synchronises and resets SoC to 100%, provided tail current and charged detection time conditions are met.
- **Tail current:** The current below which the battery monitor synchronises and resets SoC to 100%, provided charged voltage and charge detection time conditions are met. Default: 4%, adjustable if needed.
- **Charged detection time:** The duration charged voltage and tail current must be met for SoC synchronisation. Default: 3 minutes, adjustable if needed.
- **Low SoC warning level:** The level at which a warning is issued before the discharge floor has been reached.

A warning is displayed in VictronConnect and the red LED starts blinking when the warning is active.

- **Discharge floor:** This parameter has two functions:

- It defines the minimum state of charge (SoC) to which the battery may be discharged, ensuring that sufficient energy remains for self-discharge after Allowed to Discharge (ATD) is disabled.

It limits the depth of discharge to extend battery life and maintain reserve capacity, for example, to supply backup power in solar systems until recharging resumes.

When the discharge floor is reached, a Low SoC alarm is triggered in VictronConnect, the red LED lights up continuously, and Allowed to Discharge (ATD) is disabled, preventing further discharge until the SoC rises above the defined threshold.

Setting the discharge floor to zero (not recommended) disables this protection feature.



The discharge floor prevents full discharge and should be set to retain enough energy for self-discharge until recharging is possible.

- It determines the 'Time remaining' value in the VictronConnect app, calculated based on the actual discharge current and the set discharge floor.

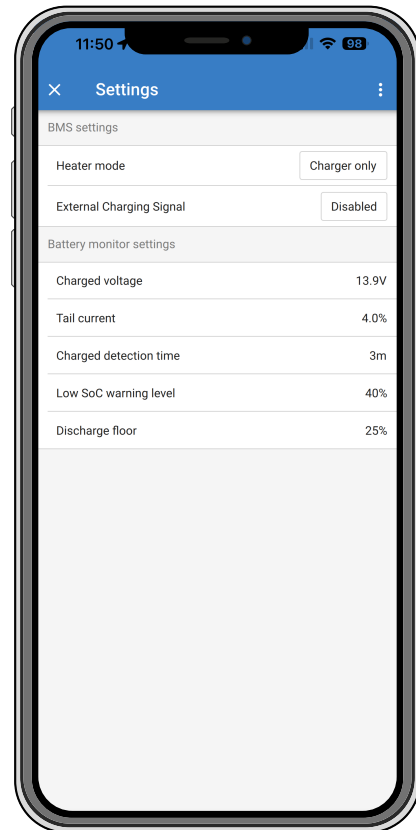

5. Operation

5.1. Monitoring & Control via VictronConnect

The battery is monitored and controlled using the VictronConnect app.

VictronConnect provides three pages for this purpose: Status, Battery, and History. Each page displays specific parameters, which are explained below.

On Android phones or tablets, VictronConnect also allows additional monitoring options. Home screen widgets can be added to display key information from Victron Bluetooth Smart devices such as the SuperPack NG battery at a glance.

VictronConnect also supports Android Auto, allowing key information from Victron devices, such as the SuperPack NG battery, to be shown on the vehicle's infotainment display. Any Victron devices listed under "My devices" in the VictronConnect device list are available on the Android Auto screen. For details, refer to the VictronConnect manual.

Status page:

The Status page displays real-time information about the battery.

- **State of Charge:** Indicates the battery's charge level in percent.
- **Mode:** Shows the battery status (On or Off) and allows switching the battery off with a tap, which disables both charging and discharging of the battery.
When the battery is switched off using the mode button, Bluetooth remains active.
- **Allowed to charge:** Indicates whether charging is permitted. The status shows "No" if:
 - The battery temperature is below 5 °C.
 - The battery temperature too high.
 - One or more battery cell voltages have reached the high cell voltage threshold (hardcoded in the battery).
 - The battery is switched off using the mode button.
- **Allowed to discharge:** Indicates whether discharging is permitted. The status shows "No" if:
 - The configured Discharge floor has been reached.
 - One or more cells have reached the hard-coded low cell voltage threshold.
 - The battery is switched off using the mode button.
 - Note: "Pre-Alarm" is displayed in the event of a pre-alarm condition.
- **External signal:** Displays the status of the External Feedback Signal (EFS).
- **Battery heating:** Battery heating: Indicates whether the internal battery heater is currently active (On) or inactive (Off).
- **Voltage:** The battery voltage as reported by the battery.
- **Current:** The current flowing through the battery, as reported by the battery.
- **Power:** The battery power as reported by the battery.
- **Consumed Ah:** The ampere-hours consumed since the last full charge cycle.
- **Time remaining:** The estimated time remaining, based on current consumption, until the **Discharge floor** is reached.

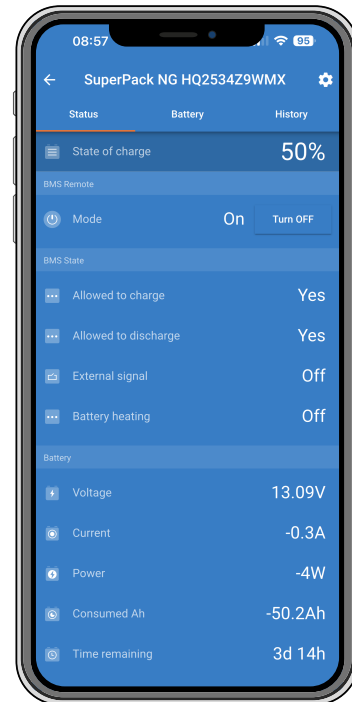
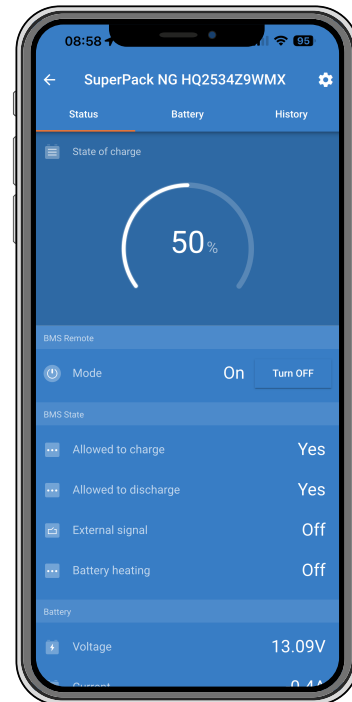

Battery page:

The Battery page provides information about the battery and detailed data.

Battery information

- **Balancer status:** Shows the current cell balancing status. Possible states:

- **Unknown:** The current status is not available. Possible reasons:
 - The battery has not been fully charged for more than 30 days.
 - The battery was recently added to the system.
 - The state of charge is unknown.

In all cases, start a new charging cycle.

- **Balanced:** All cells are balanced.
- **Imbalanced:** A cell imbalance has been detected. Perform a full charge cycle to rebalance the cells.
- **Balancing:** The battery is currently charging, and cell balancing is in progress.
- **Min cell voltage:** The lowest cell voltage detected.
- **Max cell voltage:** The highest cell voltage detected.
- **Min cell temperature:** The lowest cell temperature detected.
- **Max cell temperature:** The highest cell temperature detected.

- **Individual battery information**

The lower section displays details for the selected battery.

Displayed information includes:

- battery serial number, nominal capacity, firmware version, battery temperature, voltage, current, and individual cell voltages.



History page:

The History page displays long-term battery statistics since installation or the last history reset.

The history data can be reset using the Reset history button at the bottom of the page. However, the history should not be reset, as this data is essential for diagnosing potential battery issues.

- **Deepest discharge:**
- **Cumulative AH drawn:**
- **Discharged energy:**
- **Charged energy:**
- **Synchronisations:**
- **Cycles:**
- **Last full charge:**
- **Minimum battery voltage:**
- **Maximum battery voltage:**
- **Min cell voltage:**
- **Max cell voltage:**
- **Min cell temperature:**
- **Max cell temperature:**
- **Last error:**

**5.1.1. Instant Readout**

VictronConnect can display key battery data directly on the Device List page—without needing to connect to the product. This includes visual notifications for warnings, alarms, and errors, allowing quick diagnostics at a glance.

Instant Readout is disabled by default and must be enabled if you wish to display this data. When VictronConnect is first installed, you will be prompted to enable the feature.

Available parameters:

- **Battery voltage**
- **Battery current**
- **State of charge**
- **Remaining time**
- **Battery temperature**
- **Consumed Ah**
- **Visual notifications for warnings, alarms and errors**

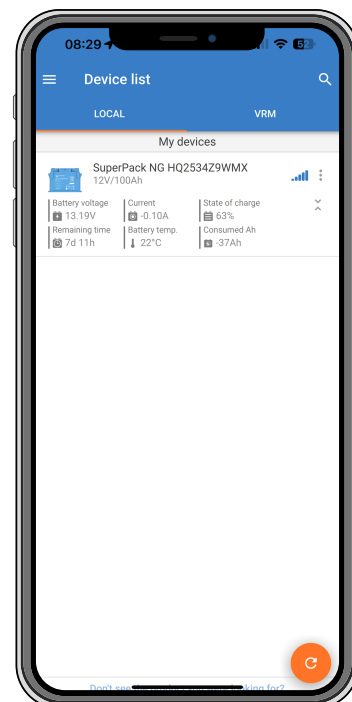

For details on enabling Instant Readout, refer to the VictronConnect manual, available on the [VictronConnect download page](#).

5.2. Charging

The Lithium SuperPack NG battery can be charged with any battery charger, provided it has a Lithium Iron Phosphate (LFP) charging profile, or a user-defined preset.

Using the correct charging parameters ensures optimal performance, safety, and service life. Refer to the [Battery Specification \[28\]](#) for the detailed charging settings.

Charging characteristics

- The Bulk/Absorption voltage defines the level at which the battery is charged to full capacity. Once this voltage is reached, the current will gradually decrease until the battery is fully charged and the cells are balanced.
- The Float voltage maintains the battery at full charge without overcharging it. This stage can be held indefinitely when the system is on standby or under light load.
- Charging stops automatically when the internal Battery Management System (BMS) detects that all cells are balanced and fully charged.

Charging conditions

- Charging is only permitted when the battery temperature is between 0 °C and 60 °C. Below or above this range, the BMS will block charging to protect the cells.
- When the temperature is too low for charging, the internal heater activates when a charger is connected (default setting). Charging will resume as soon as the cell temperature is above 0 °C.
- The battery may be charged from any DC source, including alternators, DC-DC chargers, solar charge controllers, or mains-powered chargers, as long as the voltage and current limits are within specification.
- When the battery is switched off via the VictronConnect app or the on/off push button, charging and discharging are disabled. Switching the battery off via the app keeps the Bluetooth connection active and is therefore not suitable for long-term storage.
- Recondition or equalisation modes must not be used, as they apply voltages too high for LFP chemistry.

Solar charging

When charging from a solar system, use an MPPT solar charge controller with the appropriate LFP profile (for example, Victron SmartSolar or BlueSolar).

Ensure that the charge controller's voltage limits match the recommended values shown in the table above.

Alternator charging

When charging from an engine alternator, the alternator must be protected from overload.

Use a DC-DC charger between the alternator and the battery to limit current and voltage.

Victron DC-DC chargers (such as the Orion-Tr Smart and Orion XS series) provide a safe and efficient solution for LFP charging from alternators.

5.3. Discharging

The SuperPack NG battery can supply power to DC systems or inverters within the specified limits. The BMS continuously monitors voltage, current and temperature to ensure safe and reliable operation.

Discharge characteristics

- The battery can deliver high discharge currents up to 2C, depending on the State of Charge, State of Health, and ambient temperature. Peak currents can be sustained for a few seconds. Consider 2C as the maximum for peak power demand, with higher currents only permissible as short transient peaks lasting a few seconds.
2C should be treated as peak current for short-duration high power demand. For continuous operation and system sizing, use 0.5C to reduce heat build-up, prevent component overheating, avoid triggering temperature-related safety protections, and optimise battery lifespan.
- The BMS automatically disconnects the loads and prevents discharging when the low-voltage cut-off is reached. A warning (W-B01) is issued. If the condition is not cleared within 30 seconds, ATD (discharge) is disabled and an alarm (A-B01) is raised. The status is cleared once the battery returns within the operational range.
- Discharge is automatically re-enabled once the battery voltage or temperature returns to a safe level.

Discharge conditions

- Discharging is only permitted when the internal battery temperature is between $-30\text{ }^{\circ}\text{C}$ and $60\text{ }^{\circ}\text{C}$. Outside this range, the BMS disables discharging to protect the cells.
- When the battery is switched off via the VictronConnect app or the On/Off push button, discharging is disabled.

Recommended practices

- Avoid deep discharges below 10 % SoC whenever possible.
- Use the Low SoC warning level and Discharge floor settings to limit the depth of discharge. A reduced discharge depth improves battery longevity and maintains reserve capacity for backup power.
- Regularly review discharge data in the VictronConnect history page to identify abnormal usage patterns.
- During extended storage, disconnect all loads to prevent over-discharge caused by parasitic consumption. The best practice is to switch the battery off using the push button, as this also disables the internal Bluetooth interface.

5.4. Reset to factory defaults

The Lithium SuperPack NG battery can be reset to factory settings via the VictronConnect app.

How to reset:

1. Open VictronConnect
2. Tap the cogwheel icon to access Settings.
3. Tap the three vertical dots in the Settings menu.
4. Select Reset to defaults, then confirm with Yes.

The following settings will be restored to their default values:

- Charged voltage
- Tail current
- Charged detection time
- Low SoC warning level
- Discharge floor

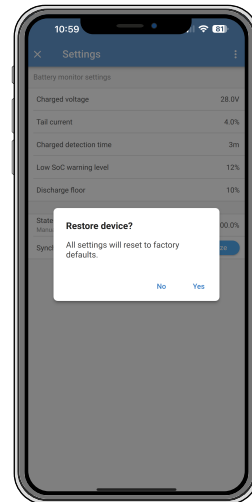

5.5. Bluetooth reactivation

If Bluetooth has been deactivated for the battery in VictronConnect, for example for security reasons, it can be reactivated as follows:

1. Switch the battery off and on again.
2. After power-up, Bluetooth will remain enabled for approximately 30 seconds.
3. Open VictronConnect within this time and connect to the battery.
4. Go to the product information page.
5. Re-enable Bluetooth to keep it active.

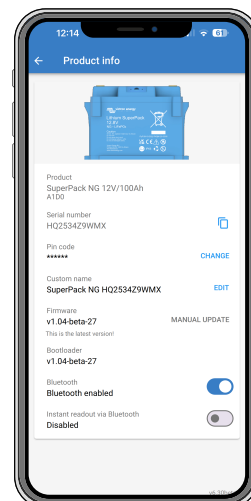

6. Troubleshooting

6.1. LEDs, Warnings, Alarms & Error Codes

LEDs

The battery is equipped with two indicator LEDs: the Bluetooth Status LED and the Error LED. These LEDs indicate the current operating state of the battery and signal any warnings or faults.



The following tables list all LED indications and their meanings.

Bluetooth Status LED	Description
Off	The battery is switched, or Bluetooth is disabled in the VictronConnect app.
Blue on	A Bluetooth device is connected.
Blue blinking	Bluetooth is active but no device is connected.

Error LED	Description
Off	No warning/alarm/error active.
Red blinking	A warning is active.
Red on	An alarm and/or error is active.

During a firmware update, the Bluetooth and Error LEDs blink simultaneously, indicating that the update is in progress.

Warnings, Alarms & Error Codes

- If the red LED lights up or blinks, open the VictronConnect app and connect to the battery to view the warning, alarm or error code and take appropriate action.
- A warning indicates a condition that may lead to a system shutdown if not resolved.
- An alarm indicates the reason for a shutdown that has already occurred. In the example shown, discharging is no longer allowed due to a Low SoC alarm, which was triggered by the Discharge floor setting in VictronConnect.
- When ATC and/or ATD indicates "No", VictronConnect also shows a circled "i" icon next to ATC and/or ATD. Tap the "i" icon to view the off-reason. See also the [ATC / ATD off-reasons in VictronConnect \[27\]](#) section.

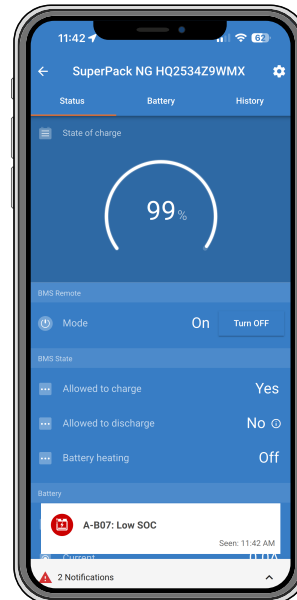

Warning codes

VictronConnect warning code	Message	Instructions / Remarks
W-B01	Low cell voltage	Charge the battery or reduce the load to prevent an imminent system shutdown.
W-B02	High current	Reduce the current to prevent an imminent system shutdown. Do this by reducing the load or by turning loads off.

VictronConnect warning code	Message	Instructions / Remarks
W-B06	Load will disconnect	The loads will be turned off after 30 seconds if the fault is not resolved, for example due to low battery voltage. This warning is always shown together with the reason for the impending load disconnection.
W-B07	Low SoC	Charge battery or reduce load to prevent imminent system shutdown.
W-B11	Cellguard Firmware cannot be updated	Follow recovery document (cellguard could not enter bootloader mode and needed a powercycle)

Alarm codes

VictronConnect alarm code	Message	Instructions / Remarks
A-B01	Low cell voltage	Charge battery. The system will turn the loads back on when the battery is sufficiently charged.
A-B02	High current	Reduce charging current or turn off some loads. The system will try to reenale chargers or loads in 5 minutes.
A-B03	High BMS temperature	Check the ambient temperature and verify that the cooling fans are operating.
A-B06	Load disconnected	The loads have been turned off via the ATD contact. Resolve this alarm by charging the battery. If not resolved, eventually the contactor will open and the DC system will be disconnected.
A-B07	Low SoC	Charge battery. The system will turn the loads back on when the battery is sufficiently charged.
A-B08	Low bank voltage	Charge battery. The system will turn the loads back on when the battery is sufficiently charged.
A-B09	High battery temperature	The battery temperature is too high for charging. Try to reduce the ambient temperature.
A-B13	Low battery temperature	Try to increase the ambient temperature.

Error codes

VictronConnect error code	Message	Instructions / Remarks
E-B11	Hardware error	Contact your Victron dealer.
E-B25	Pre-charge error	The load resistance is too low to pre-charge the loads. Disconnect or reduce some DC loads.
E-B35	Pre-charge timeout	The load capacity is too high to pre-charge. Disconnect some DC loads.
E-B36	ATC/ATD failure	Check ATC/ATD wiring and make sure that all loads and chargers are controlled by ATC or ATD.
E-B42	High cell voltage	
E-B43	External disconnection signal	SuperPack extern signal triggered.
E-B44	Battery safety lock	Active when a cell voltage is below 1.85V for more then 30 seconds. Both charging and discharging are disabled in this case. Can only be reset by a power-cycle.
E-B116	Calibration lost	Contact your dealer.
E-B119	Settings data lost	Settings data is corrupt. Go to the settings page and reset to defaults.

6.2. Self-restoring protection mechanisms

The SuperPack NG battery includes several protection mechanisms that automatically disable charging and/or discharging when unsafe conditions are detected. In most cases, the battery attempts to recover automatically once the condition is removed. This section explains the behaviour of these self-restoring protections and when manual intervention is required.

Short circuit protection

A short circuit is detected and interrupted by the hardware protection. When this occurs, the firmware attempts to recover automatically by performing a pre-charge sequence.

The battery performs up to three pre-charge attempts, with a 30-second pause between each attempt.

If, after three attempts, the short-circuit condition is still present and the output voltage does not rise, a pre-charge error (E-B25) is raised. In this state, both charging and discharging are disabled.

If the short-circuit condition is later removed (the load voltage drops below the defined threshold), charging and discharging are automatically re-enabled.

If, during the recovery attempts, the output voltage does rise but normal operation cannot be fully restored, a pre-charge timeout is raised. In this case, discharging is disabled while charging remains allowed.

After a pre-charge timeout, the battery waits 10 minutes before repeating the pre-charge sequence (three attempts). This cycle is repeated automatically until the output can be enabled again.

Overcurrent protection

If an overcurrent condition is detected during charging or discharging, the affected action is disabled immediately. Overcurrent protection is activated within 10 seconds once the detected current exceeds the maximum continuous current threshold. The intervention time is reduced if the detected current exceeds 3C.

After a delay of up to 5 minutes, charging or discharging is automatically re-enabled. If an overcurrent condition is detected again, the same process is repeated.

There is no permanent lockout for overcurrent protection. The battery will continue to disable and re-enable charging or discharging in 5-minute cycles until the overcurrent condition is resolved.

Low-voltage protection

The BMS automatically disconnects the loads and prevents discharging when the low-voltage cut-off is reached. A warning (W-B01) is issued. If the condition is not cleared within 30 seconds, ATD (discharge) is disabled and an alarm (A-B01) is raised.

The status is cleared once the battery returns within the operational range.

Temperature protection behaviour

Over-temperature and under-temperature protections are self-restoring. Charging and/or discharging are automatically re-enabled once the battery temperature returns within the specified operating range. No manual intervention is required.

Low-voltage safety lock-down

The low-voltage safety lock-down is an additional layer of protection that can occur if the cells continue to discharge due to self-discharge.

If a cell voltage drops below the safety lock-down threshold, discharging is disabled. After 30 seconds, charging is also disabled and the Battery Safety Lock error (E-B44) is triggered.



This condition is not self-restoring. Recovery is only possible by performing a full power cycle of the battery after the underlying cause has been resolved.



Avoid allowing the battery to reach this state. Deep discharge can cause permanent cell damage and may invalidate the warranty. Always ensure the battery remains sufficiently charged, especially during storage. If this condition does occur, follow the [Very low battery voltage recovery procedure \[26\]](#) in the next section.

6.2.1. Very low battery voltage recovery procedure

If a battery is discharged too deeply, its terminal voltage can fall well below the nominal 12 V (24 V or 48 V). If the battery voltage drops below 10 V (20 V or 40 V for 24 V and 48 V systems respectively), or if any cell voltage falls below 2,5 V, permanent battery damage may occur. This condition invalidates the warranty. The lower the battery or cell voltage, the more severe the damage is likely to be.

In such cases, it may be possible to attempt recovery using the low-voltage recharge procedure described below. However, recovery is not guaranteed. There is a realistic risk that the battery has suffered permanent cell damage, which may result in moderate to severe capacity loss even if recovery appears successful.

Low-voltage recovery charge procedure

This recovery procedure must only be performed on a single battery. If the system contains multiple batteries, disconnect them and repeat the procedure individually for each battery.



This process is potentially hazardous. A supervisor must be present at all times.

1. Set the charger or power supply to:
 - 13,8 V for 12 V batteries
 - 27,6 V for 24 V batteries
 - 55,2 V for 48 V batteries
2. If any cell voltage is below 2,0 V, charge the battery with a current of 0,1 A until the lowest cell voltage rises to at least 2,5 V. Closely monitor the battery during this phase. If the battery becomes hot or starts to bulge, stop charging immediately. In this case, the battery is irreparably damaged and must not be used further.
3. Once the lowest cell voltage has risen above 2,5 V, increase the charge current to 0,1 C.
For a 100 Ah battery, this corresponds to a charge current of 10 A. For a 100Ah battery, this is a charge current of 10A.
4. Record the initial battery terminal voltage and individual cell voltages.
5. Start charging.
During this phase, the BMS may repeatedly switch the charger on and off. This behaviour is normal when there is a significant cell imbalance.
6. Record the battery and cell voltages at regular intervals. The cell voltages should begin to rise during the first part of the charging process.
If the voltage of any cell does not increase within the first 30 minutes, stop the procedure and consider the battery unrecoverable.
7. Monitor the battery temperature regularly.
If a sharp temperature increase is observed, stop charging immediately and consider the battery unrecoverable.
8. Once the battery reaches:
 - 13,8 V (27,6 V or 55,2 V),
increase the charge voltage to:
 - 14,2 V (28,4 V or 56,8 V),
and increase the charge current to 0,5 C.
For a 100 Ah battery, this corresponds to a charge current of 50 A.
9. During this stage, the cell voltages will rise more slowly. This is normal.
10. Leave the charger connected for 6 hours.
11. Afterwards, check the cell voltages. They should be within 0,1 V of each other.
If one or more cells show a significantly higher deviation, consider the battery damaged.
12. Disconnect the charger and allow the battery to rest for several hours. Then measure the battery voltage. It should stabilise well above:
 - 12,8 V (25,6 V or 51,2 V),
typically around:
 - 13,2 V (26,4 V or 52,8 V) or higher.
The cell voltages should still be within 0,1 V of each other.

13. Allow the battery to rest for 24 hours and measure the voltages again.

If the battery voltage has fallen below 12,8 V (25,6 V or 51,2 V), or if a noticeable cell imbalance is present, the battery should be considered damaged beyond recovery.

6.3. ATC / ATD off-reasons in VictronConnect

When Allow To Charge (ATC) or Allow To Discharge (ATD) is inactive, VictronConnect displays a specific off-reason explaining why charging or discharging is currently disabled.

The off-reason can be viewed by tapping the circled “i” icon shown next to the ATC or ATD status when it indicates “No”.

Off-reasons can result from internal battery protection mechanisms, configuration settings, temperature limits, remote control inputs, or system error conditions. Each off-reason is accompanied by a short description and, where applicable, guidance on corrective actions.

Depending on the condition, an off-reason may apply to ATC, ATD, or both. Reviewing the off-reason helps determine whether the restriction is temporary, configuration-related, or caused by a protection or fault condition, and supports correct troubleshooting.

The following table provides an overview of all possible ATC and ATD off-reasons as shown in VictronConnect.

VictronConnect off-reason	Description	Advice	Trigger condition	ATC	ATD
#1: Disabled by battery	Battery prevents [charging discharging]. This may occur if there is no communication with the battery (yet) or if the battery configuration is invalid.		No battery communication Invalid battery configuration Invalid battery voltage	Yes	Yes
#3: High temperature	The temperature is too high. This is a part of the battery protection mechanism and it is not necessarily indicating a problem.	Check the ambient temperature and/or whether the fans are running.	FET temperature too high Cell overtemperature	Yes	Yes
#5: Internal reason	The device is in alarm state and it is preventing normal operation.	Check the alarm notifications and take the appropriate actions to clear it.	System error (User Settings Failure, Calibration Data Lost, ATC/ATD Failure, External Disconnection Signal)	Yes	Yes
#6: Overloaded			Pre-charge timeout (ATD only) or pre-charge error	Yes	Yes
#8: Disabled by the user	Remotely switched off by VictronConnect.	Check that the 'On/Off' settings are configured as desired.	Switched off via VictronConnect	Yes	Yes
#9: Low temperature	The temperature is too low. This is part of the battery protection mechanism and it is not necessarily indicating a problem.		Cell undertemperature	Yes	Yes
#10: High voltage	Voltage level of one or more cells is too high.		Cell overvoltage	Yes	No
#11: Low voltage	Voltage level of one or more cells is too low.		Battery bank undervoltage Cell undervoltage	No	Yes
#12: High current	[Charge Discharge] current is too high.		Battery overcurrent	Yes	Yes
#13: Low SoC			SoC below discharge floor	No	Yes

7. Technical Data

7.1. Battery Specification

VOLTAGE & CAPACITY	SuperPack 12,8V/100 Ah NG	SuperPack 12,8 V/200 Ah NG	SuperPack 25,6 V/100 Ah NG	SuperPack 25,6 V/200 Ah NG	SuperPack 51,2 V/100 Ah NG
Part Number	BAT512110740	BAT512120740	BAT524110740	BAT524120740 ¹⁾	BAT548110740 ¹⁾
Nominal capacity @ 25 °C ²⁾	12,8 V		25,6 V		51,2 V
Nominal energy @ 25 °C ²⁾	100 Ah	200 Ah	100 Ah	200 Ah	100 Ah
Nominal energy @ 25 °C	1280 Wh	2560 Wh		5120 Wh	
Capacity loss / Energy loss	(per 100 cycles, @ 25 °C, 100 % DoD): <1 %				
Round trip efficiency ³⁾	93 %				
CYCLE LIFE 25 °C (capacity ≥ 80 % of nominal)³⁾					
Cycle life	2500 cycles @80 % DoD 3000 cycles @70 % DoD 5000 cycles @50 % DoD				
DISCHARGING					
Recommended discharge current (continuous use)	50 A	100 A	50 A	100 A	50 A
Max continuous discharge current ⁸⁾	200 A	400 A	200 A	400 A	200 A
End of discharge voltage	11,2 V		22,4 V		44,8 V
Internal resistance	2 mΩ	1 mΩ	4 mΩ	2 mΩ	8 mΩ
CHARGING					
Recommended charging voltage	14 V		28 V		56 V
Float voltage	13,5 V		27 V		54 V
Charging voltage range	[13,5 - 14,2] V		[27 - 28,4] V		[54V - 56,8] V
Recommended charging current	30 A	60 A	30 A	60 A	30 A
Max continuous charging current ⁸⁾	100 A	200 A	100 A	200 A	100 A
FEATURES					
Hardware connection / System max current	Short circuit above 800 A				

Software protections	Overvoltage, Undervoltage, Overtemperature, Undertemperature, Overcurrent		
Wired communication	External Feedback Signal (EFS)		
Bluetooth	Yes, VictronConnect App		
GUI / Status indication	Push button (On/Off), BLE LED, Error LED		
Self-heating max power	65 W	130 W	260 W
OPERATING CONDITIONS			
Parallel configuration	Yes, unlimited energy expansion, with power expansion limited to the system's maximum current		
Series configuration	No		
Operating temperature	Charge ⁷⁾ and Discharge: -30 °C to +60 °C		
Humidity Operating Range (non condensing)	<90 % RH		
Storage temperature	Recommended [10 - 35] °C Expanded [-40 to +65] °C ⁴⁾		
Max storage time @ 25°C	1 year with at least initial remaining SoC >50 %		
Protection class	IP65		
MOUNTING			
Power connection (threaded insert)	M8 female 20 mm including nut screws		
Mounting options	Upright and on its long side, maintain flat horizontal support		
Dimensions [LxWxH] (mm) ⁵⁾	273 x 173 x 173 ⁶⁾	466 x 198 x 173	871 x 198 x 173
Weight (kg)	10,7	20,5	41
External Feedback Signal (EFS) Connector	External Feedback Signal connector for SuperPack NG (included) - Victron part number: SPR00310		
STANDARDS			
Safety	Cells: IEC62619 UL1973 UL 9540A Battery: IEC62619 (pending)		
EMC	EN 61000-6-3, EN 61000-6-2		
Performance	IEC62620 (pending)		
Transportation	UN 38.3		
Automotive	ECE R10-7	ECE R10 pending	

Notes	<ol style="list-style-type: none">1) Product launch after Q1 20262) Discharge current $\leq 1C$3) 25 °C and 0.5C cycling4) Performances might be reduced5) Additional height of 15 mm for terminal screws6) Compatible with BCI Group 49 dimensions7) Below 0 °C, charging is suspended while the internal self-heating function warms the cells and automatically resumes once a safe charging temperature is reached.8) Above this limit, protection is triggered within 10 seconds.
-------	--

7.2. Enclosure Dimensions

